

# PureWaterCooler™

by VERTEX



**NEW** PureChill-9100



## Cleaner. Safer. Better.

*The latest addition to the Vertex family of products brings innovation for safer water with less hassle.*

The newest VERTEX **PureWaterCooler** uses **PureChill™** Technology to eliminate the need for an open reservoir for cold water storage. The closed system keeps environmental contaminants out so there is no need for costly in-tank sanitization. The water is safely dispensed directly to your cup.



# PureChill-9100

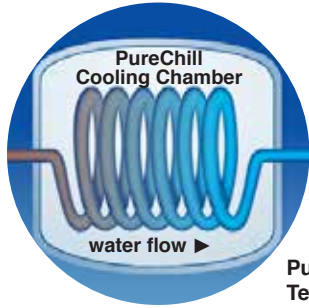

PureChill Cooling Technology



Integrated Filter Monitor



ProTekk Auto-Safety Shut-off valve

## Standard Features

- PureChill™ Technology
- No need for expensive UV and Ozone in tank sanitizers
- Integrated Filter Monitor ensures freshly filtered water
- ProTekk™ Auto Safety-Shut-Off Valve provides peace of mind
- Two temperature system  
Cold: 37-50° F, Adjustable • Hot: 180° F, Autocontrol  
LED indicator for Hot and Cold water on the front panel
- Tall fill opening allows larger cups, mugs or reusable bottles
- Hygienic dispensing touch pad control with no-touch dispensing faucet
- Easy to clean control panel
- Individual on/off control switches for cold and hot water on rear panel
- Standard Dual-Cartridge filtration system
- Filter assembly is front door accessible.
- Attractive LED lighted dispense area
- Award winning design
- 1 year limited warranty
- 3 year compressor warranty

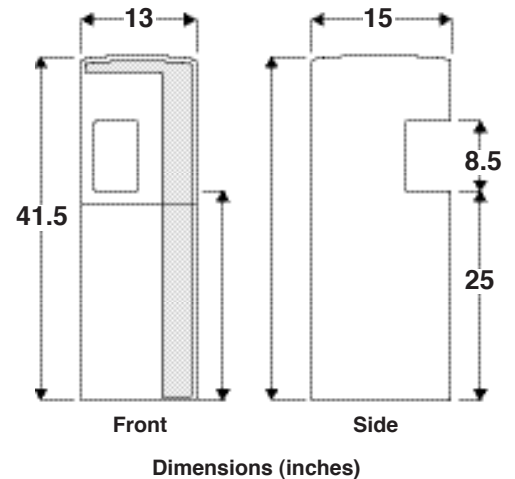

## Specifications

Shipping Weight: 60 lb.  
 Dimension: 13"W x 15"D x 41.5"H  
 Cooling Rate: 2.1 gal/hr 37-50 °F  
 Hot tank volume .5 gal  
 Heating Rate: 1.3 gal/hr 180 °F  
 Voltage: 115 VAC  
 Power Required: 600w max

ADA compliant



## Filter System

Standard Filter **9100F**  
**Stage 1:** 5 micron Sediment  
**Stage 2:** 10 micron Activated Carbon  
 Reverse Osmosis Filter **9100R**  
 Above 2 stages plus  
**Stage 3:** 100-GPD RO Membrane  
 Automatic tank full control  
 Fully assembled

## ORDERING

2-Temp Model - 50 GPD Reverse Osmosis	<b>PWC-9100R</b>
2-Temp Model - Standard Filtration	<b>PWC-9100F</b>
2-Temp Model	<b>PWC-9100</b>
Replacement Filters	Sediment <b>TF-4113</b>
	Carbon <b>TF-4115</b>
	RO membrane, 100 GPD <b>MA-4205</b>

Authorized Dealer